

B&H RISER INSTALLATION PROCEDURE

The Harrington Corporation

Phone: 434-845-7094

Fax: 434-845-8562

Email: sales@harcofittings.com

The logo consists of a blue diamond shape with a white border. Inside the diamond, the word "HARCO" is written in a bold, blue, sans-serif font, centered horizontally and vertically.

HARCO

Riser General Arrangement

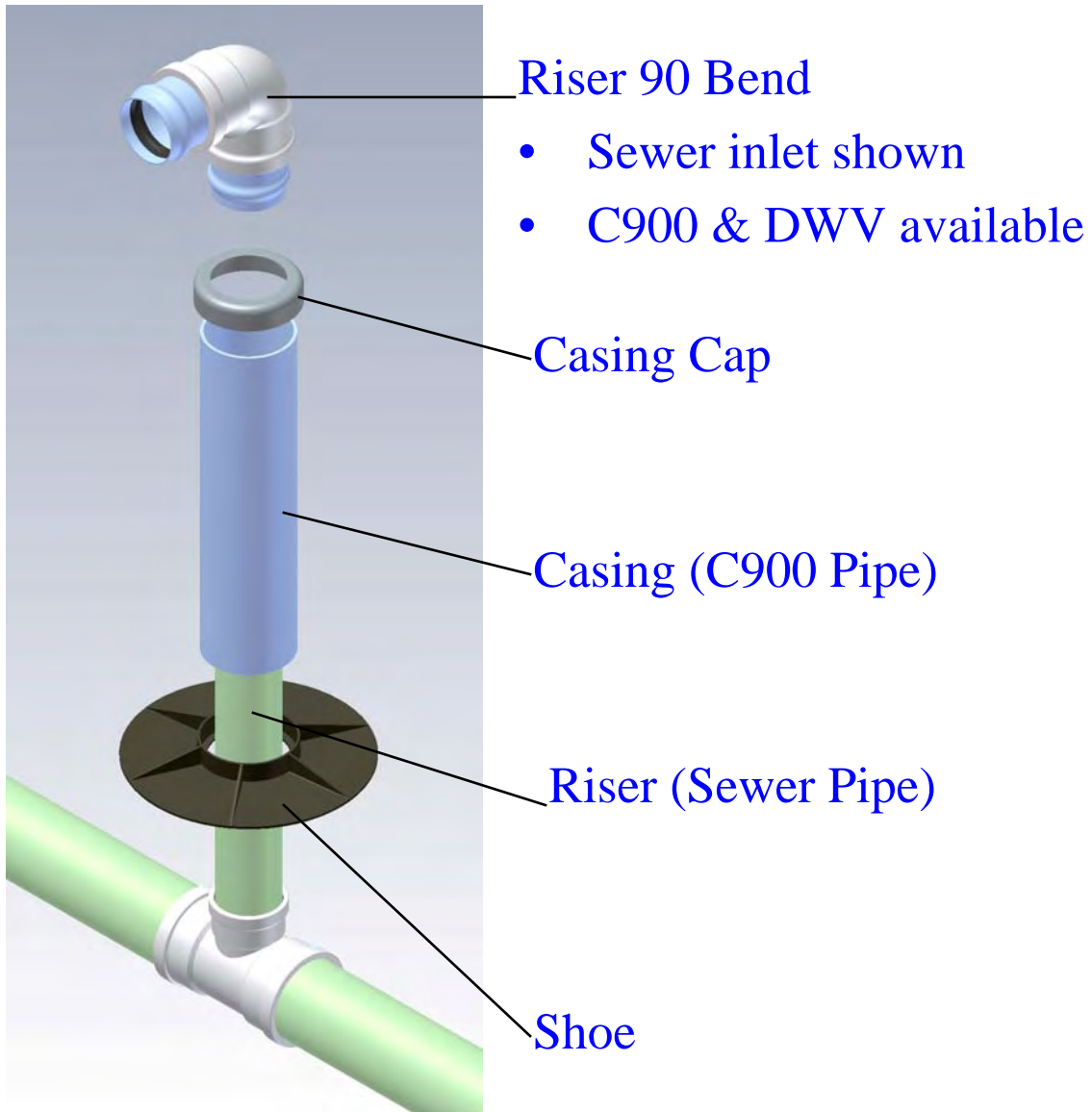

Exploded View

HARCO

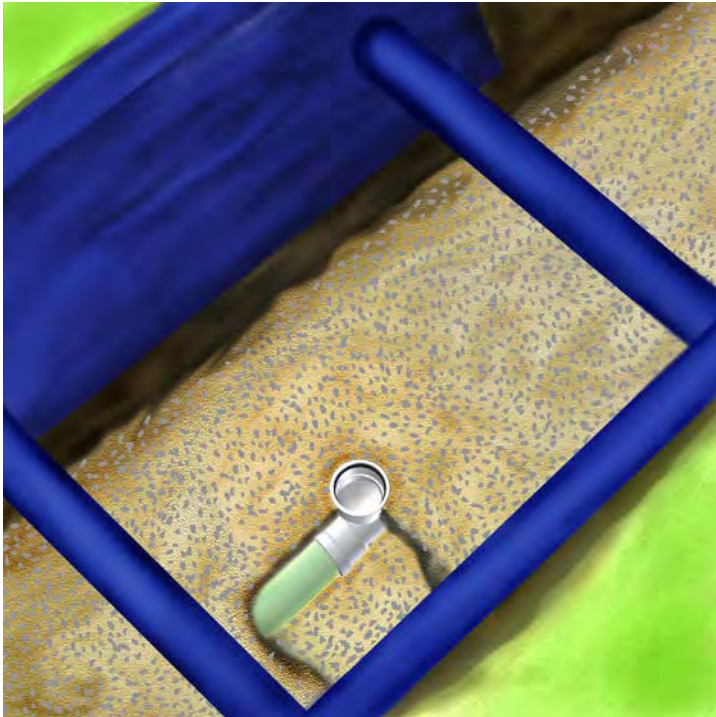

1. Embed mainline fitting with compacted crushed stone to the top of the branch outlet

2. Embedment material should be Class 1A or Class 1B installed per ASTM D2321



3. Place casing shoe centered and level over sewer main branch

HARCO

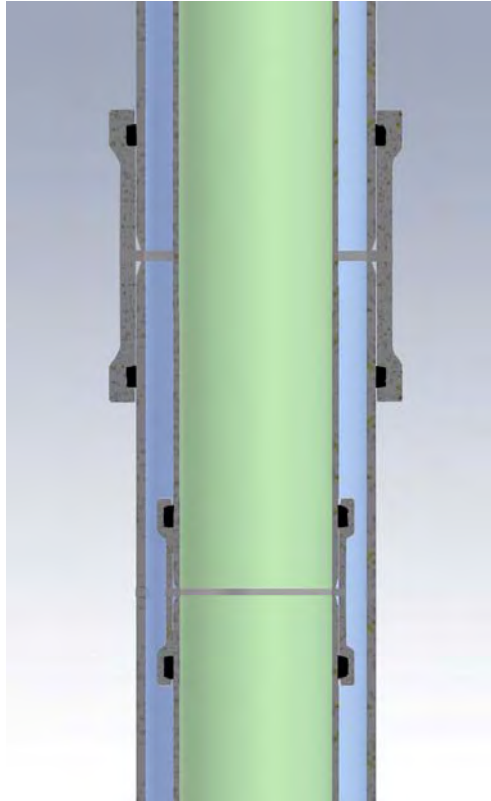

4. Use line couplings to join lengths of riser pipe and casing pipe as required

5. Use sewer pipe for vertical riser.



6. Install riser pipe being sure not to over insert or over deflect pipe in bell.

HARCO



7. Use C900 pipe for casing.

8. Make square cut on end of casing.



9. Lower casing over riser pipe. Avoid loading or deflection of riser.



10. It may be easier to cut and join shorter lengths.

11. Install casing into shoe

HARCO



12. Final backfill and compaction as required.



13. Be careful not to deflect or load riser pipe.

HARCO



14. Cut casing pipe to deliver desired lateral elevation.
15. From top of casing pipe to top of lateral pipe is approximately 12" for a 6" lateral and 9.5" for a 4" lateral.
16. Bevel top of casing pipe to ease installation of casing cap

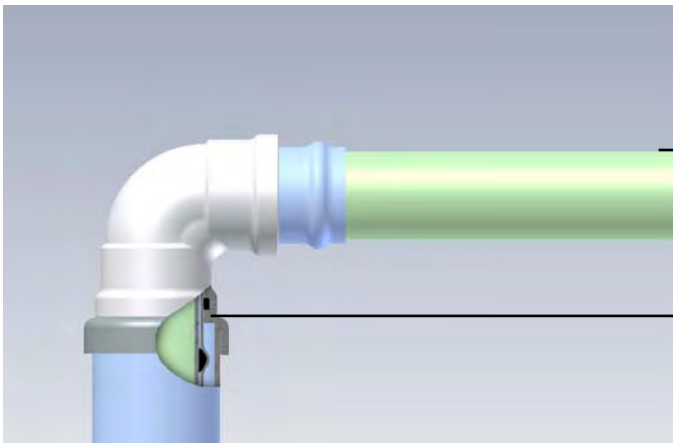

~12" for 6" lateral
~ 9.5" for 4" lateral

HARCO



17. Install casing cap

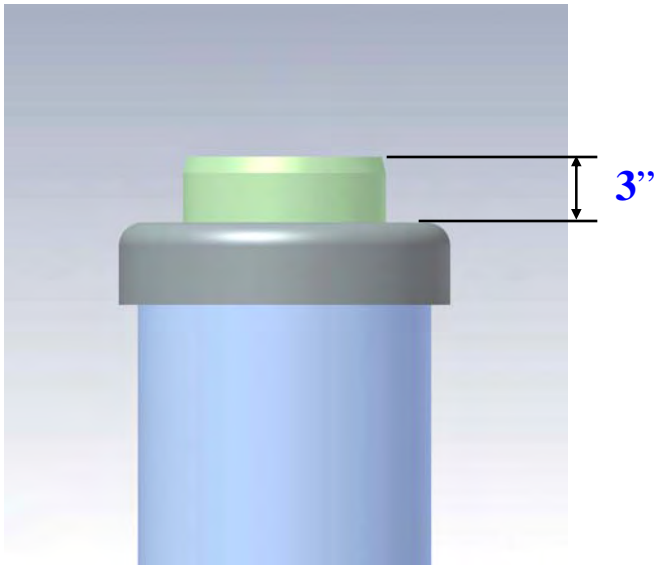

18. Cut riser pipe
3" above top
of casing cap

HARCO

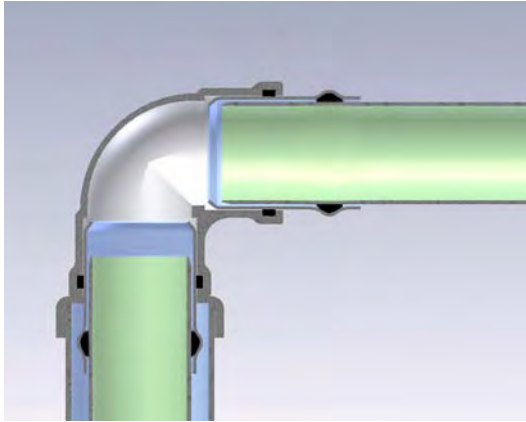

19. Bevel top of riser pipe.



20. Apply lube and install riser 90 bend



21. Install lateral pipe.

22. Provide for proper bedding and compacted embedment of lateral pipe.

HARCO